

DW(Y) - D0D2 - P

設置図
S=1:10

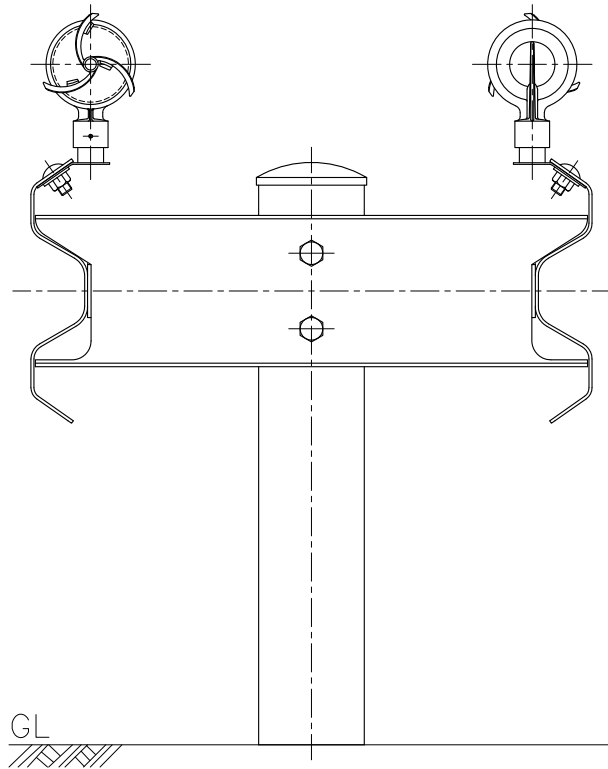

詳細図
S=1:4

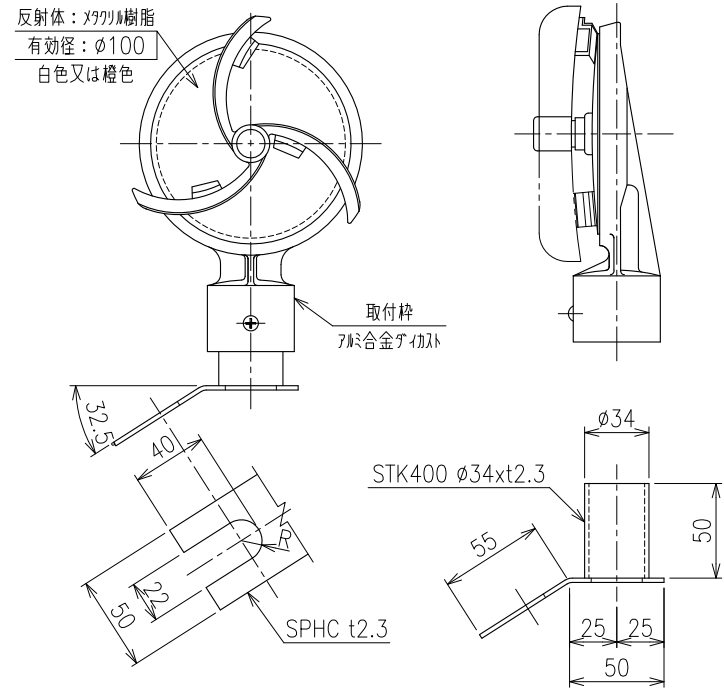

注) 溶接後 溶融亜鉛メッキ処理のこと