

DW (Y) - DOD2 (W:白 Y:橙)

(φ100 GR差込式)

設置図

S=1:12

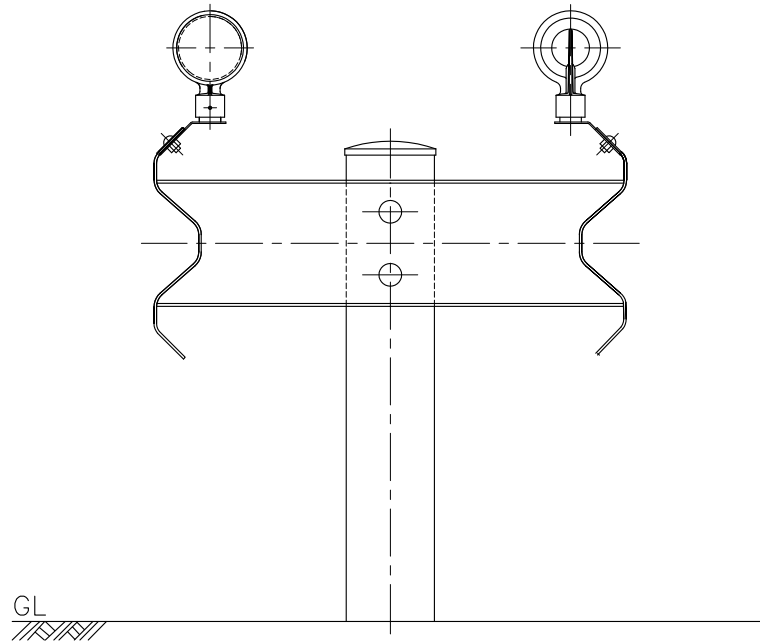

詳細図

S=1:4

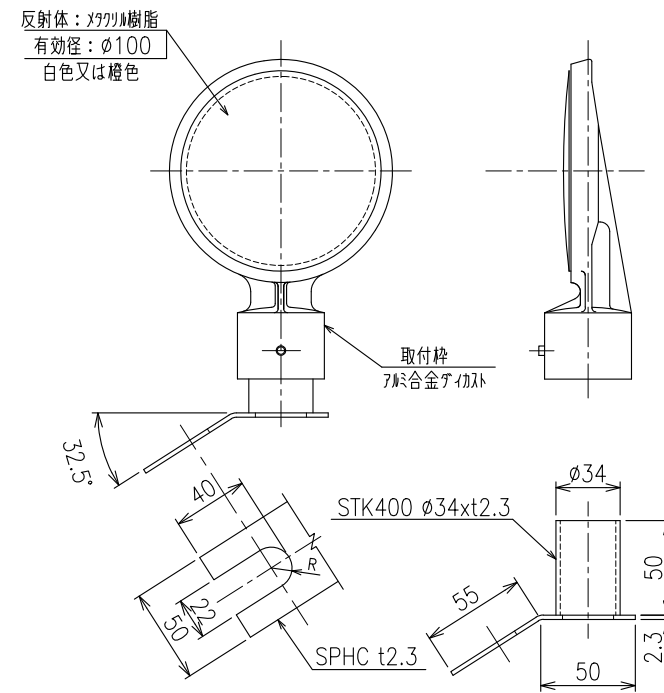

注) 溶接後 溶融垂鉛メッキ処理のこと